

MODEL 2644

3-Phase Monitor

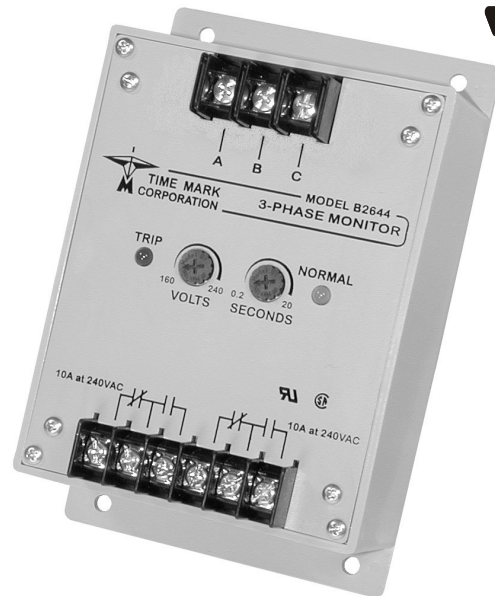

- Detects Phase Loss, Low Voltage and Phase Reversal
- Optional Restart Delay
- Automatic or Manual Reset
- 5 Year Unconditional Warranty



DESCRIPTION

The Model 2644 3-Phase Monitor continuously monitors 3-phase Wye or Delta systems for abnormal conditions.

The solid-state electronic sensing circuitry drives an internal DPDT relay, allowing the Model 2644 to operate two motor control circuits, or a control circuit and an alarm circuit. An adjustable trip delay reduces nuisance tripping caused by momentary voltage fluctuations on motor start-up.

An optional restart delay gives approximately a 3.5 minute delay when the relay drops out, to allow compressor head pressures to bleed off, in the event of short-term power failures.

Voltage adjustment ranges are sufficiently wide to allow for proper calibration to existing conditions. Both TRIP and NORM indicators are provided to aid in adjustment and system troubleshooting.

Automatic and manual reset versions are available. The Model 2644 Monitor is not sensitive to line current, and can be used with any size motor or compressor.

DIMENSIONS

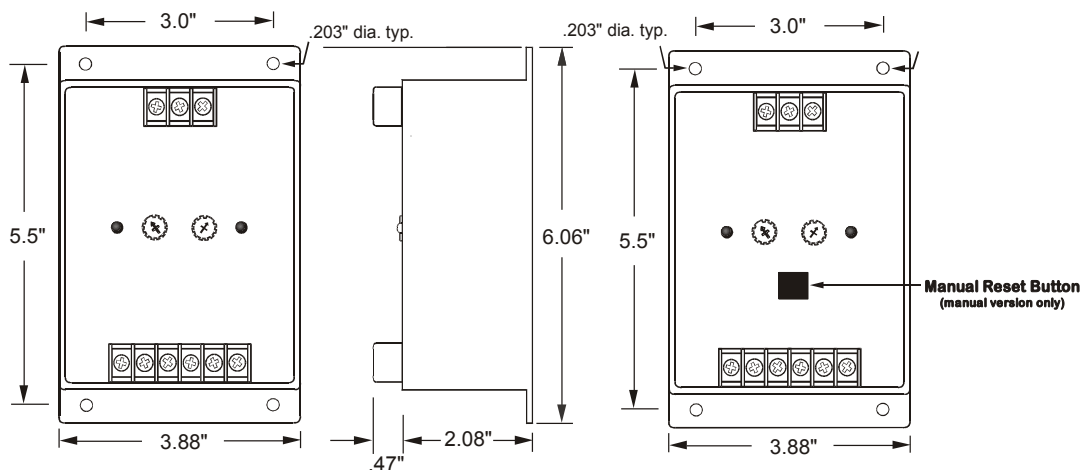

SPECIFICATIONS

AUTO Reset	A2644	B2644	C2644	D2644	EX2644
MANUAL Reset	A2644M	B2644M	C2644M	D2644M	EX2644M
RESTART DELAY	A2644R	B2644R	C2644R	D2644R	EX2644R
Nominal AC Voltage (phase to phase)	120VAC	208/240VAC	480VAC	575VAC	380VAC
Adjustment Range	85-120V	160-240V	380-480V	450-575V	300-400V
Frequency	60Hz	60Hz	60Hz	60Hz	50Hz
Power Consumption	0.75W	1.5W	4.5W	7.5W	4.5W
Transient Protection	2500 VRMS for 10ms				
Repeat Accuracy	± 0.1% of setpoint (fixed conditions)				
Response Time	Adjustable 0.2 to 20 seconds ±10%				
Dead Band	Approximately 2%				
Output Contacts	DPDT 10 amps at 240VAC resistive				
Expected Relay Life	Mechanical: 10 million operations Electrical: 100,000 operations at rated load				
Operating Temp	- 20° to +131° F				
Humidity Tolerance	0 - 97% w/o condensation				
Enclosure Material	ABS plastic				
Mounting	Surface				
Weight	9.5 oz				
Agency Approvals	All versions UL Recognized and CSA Certified				



TIME MARK
CORPORATION

11/2011
© 2011 TIME MARK CORPORATION

TIME MARK is a division of AEMT, Inc.

MODEL 2644 3-Phase Monitor

READ ALL INSTRUCTIONS BEFORE INSTALLING, OPERATING OR SERVICING THIS DEVICE.
KEEP THIS DATA SHEET FOR FUTURE REFERENCE.

GENERAL SAFETY

POTENTIALLY HAZARDOUS VOLTAGES ARE PRESENT AT THE TERMINALS OF THE MODEL 2644.
ALL ELECTRICAL POWER SHOULD BE REMOVED WHEN CONNECTING OR DISCONNECTING WIRING.
THIS DEVICE SHOULD BE INSTALLED AND SERVICED BY QUALIFIED PERSONNEL.

Installation Instructions

INSTALLATION

Turn both adjustment control potentiometers fully counter-clockwise.

Connect the 3-phase wires to the terminals marked **A**, **B** and **C**.

Connect the control wires to the terminals with the relay contact markings. The contact markings on the unit are the failed or tripped condition of the contacts. Apply power.

If the contacts do not transfer when power is applied (TRIPPED indicator on; NORMAL indicator off), press the RESET button and check that all three phases are present and of the correct voltage.

If all phases are correct, remove power from the unit, reverse any two of the **A**, **B** or **C** terminal wires (*phase rotation is reversed*), and re-apply power. The contacts should then transfer.

ADJUSTMENT PROCEDURE

Rotate the TRIP DELAY adjustment pot counter-clockwise.

Rotate the FAILURE LEVEL adjustment pot clockwise until the unit trips (NORMAL indicator off; TRIPPED indicator on).

Slowly rotate the FAILURE LEVEL adjustment pot counter-clockwise until the unit resets (TRIPPED indicator off; NORMAL indicator on). On 2644R versions there will be 3.5 minutes delay before NORMAL comes back on.

Set the TRIP DELAY adjustment to the desired amount of delay to prevent nuisance trips.

These adjustment settings will be correct for most applications. Should nuisance trips occur, even with the TRIP DELAY set, turn the FAILURE LEVEL adjustment pot slightly farther counter-clockwise. Any adjustments should be made in very small increments.

TYPICAL APPLICATION

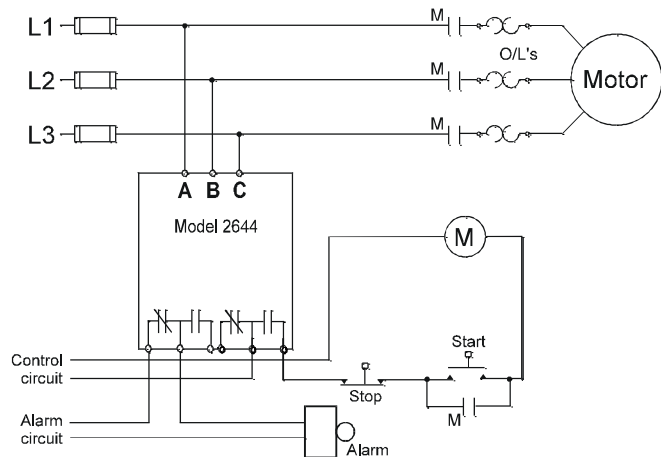

Shows No Power Applied

TROUBLESHOOTING

Should the Model 2644 3-Phase Monitor fail to operate properly, check that three phases are present and are of the correct voltage and phase rotation (*a Time Mark Model 108A or 108B Phase Sequence Detector should be used to verify phase rotation*). Check all fuses, and verify that all wiring connections are correct. Should problems persist, contact your local Time Mark Distributor, or the factory for further assistance.

WARRANTY

This product is warranted to be free from defects in materials and workmanship, and is covered by our exclusive **5-year Unconditional Warranty**. Should this device fail to operate for any reason, we will repair it for five years from the date of manufacture. For complete warranty details, see the *Terms and Conditions of Sales* page in the front section of the Time Mark catalog or contact Time Mark at 1-800-862-2875.



TIME MARK
CORPORATION

11/2011

© 2011 TIME MARK CORPORATION

TIME MARK is a division of  AEMT, Inc.